

AXCES EXHAUST SILENCERS

**INSTALLATION/MAINTENANCE
MANUAL FOR
EXHAUST
SILENCERS**



CONTENTS

INTRODUCTION	3
Installation and commissioning.....	4
General information.....	4
Spare parts information.....	4
GENERAL INFORMATION	4
IDENTIFICATION LABEL (TYPE PLATE)	5
INFORMATION CE-MARKETING	5
Accepted methods of slinging silencers.....	6
HANDLING	6
INSTALLATION	8
Silencer location/position.....	9
The layout of the main components of the gas exhaust system.....	10
Elements of flue.....	11
Anti-vibration mountings flue.....	11
Installation recommendations.....	12
INSTALLATION OF SPARK ARRESTOR SA	13
INSTALLATION OF SPARK ARRESTOR CP	14
CLEANING INSTRUCTIONS FOR SPARK ARRESTORS	15
WARNING/DANGER	16
FIRST AID CO/CO₂-POISON	17
MAINTENANCE	17
FIRST AID BURNS	17

INTRODUCTION

This installation and maintenance manual is intended for exhaust systems and silencers with or without integrated spark arrestors manufactured by Axces B.V., Netherlands. By following the guidance in this publication, you will be able to get optimal use of the silencer concerning back pressure, silencing and a prolonged lifetime. It discusses precautions, handling, mounting and maintenance of the silencer. The requirements of these guidelines are binding.



GENERAL INFORMATION

INSTALLATION AND COMMISSIONING

- Information regarding dimensions and weight is sealed on one of the end covers of the silencer.
- Under roof dry storage is required.
- The silencer can be lifted on the lifting lugs or with hoisting equipment round the body.
- Before installation remove end covers.
- In case a spark arrestor is installed type:(REAB35-IS), (ABS-IS), (CP), (SA) leave enough space around the soot container to clean it.
- Do not cover the nut cap of the soot container in the heat insulation.
- Special care must be taken to the direction of mounting. On the body of the silencer is a flow direction arrow mounted.
- Before start up check that all the bolts of the flange connections are tight, and a gasket is installed.

GENERAL INFORMATION

- AXCES silencers are designed for mounting in exhaust gas lines of diesel and gas engines.
- The working is according to the absorption and reflection principle.
- The optimal gas speed is between 35 and 50 meters per second.
- High demands on noise damping require lower gas speeds (between 25 and 35 meters per second).
- The maximum allowable temperature is 500 degrees centigrade.
- The material used is SS316L.

SPARE PARTS INFORMATION

- There are no recommended spare parts.
- All bolts and nuts have metric thread; therefore no special tools are required.

INFORMATION CE-MARKETING

The machine directive has come into force from 1 January 1995. Machines, which come on the European market, must be provided with a certificate in accordance with the directive. According to this directive, the by us delivered silencer(s) can be marked as a "machine without CE-mark, not independent operating and meant for built in". According; 89/392/EEG,91/368/EEG,93/44/EEG page. L183/2F lid. B.

IDENTIFICATION LABEL (TYPE PLATE)

On each silencer there is an identification label (type plate) with indication of the type of silencer, type of integrated spark arrestor (indicating design type), serial number and year of manufacturing. A label is shown below and an explanation of the information is given.

Type of silencer and
spark arrestor

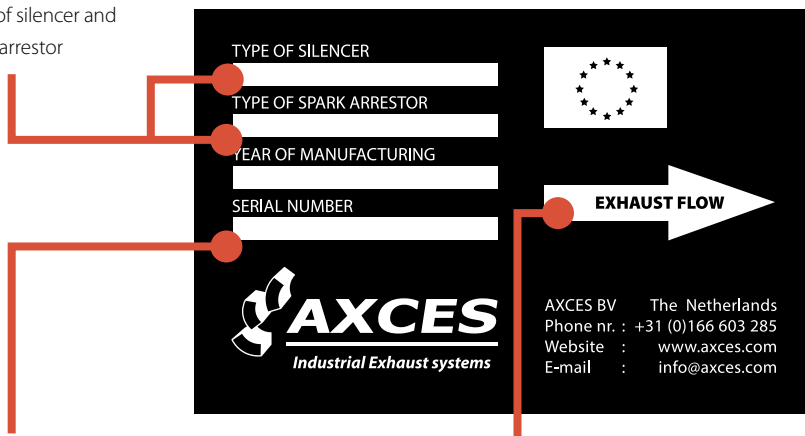

The serial number is the link for any contact to AXCES. Please have this number ready when you contact us.

Important: Silencer is constructed so that the exhaust gas has to flow in a certain direction through the silencer to give the right sound reduction and the right back pressure. This arrow indicates the flow direction.

HANDLING

Silencers have to be handled with care. Even small damages on the outer shell can change back pressure and impact the sound reduction effectiveness. Normally silencers are delivered painted with a thin layer of transport paint. The purpose of the paint is just to prevent the surface from becoming rusty before mounting. So during transport and handling care must be taken not to damage the paint. Most silencers are mounted indoors and after mounting they are insulated. In this case paint is not important after mounting. If a silencer is mounted outdoors without insulation, it must be repainted with a suitable paint for outdoor purpose and resistant against high temperatures up to 500°C.

Silence handling has the following minimum requirements:

- Sling devices connection to the lifted structure and lifting cranes must be reliable;
- Slings must exclude violation of the form and strength of the structure, as well as its fall and rollover.

In cases where the structure is not equipped with special devices (loops, pins, eyelets) for strapping silencers and spark arrestors can be used conventional banding or ropes by their binding to the knots and loops. Protective pads should be installed to prevent binding bands and ropes from chafing with piping silencers, as well as damage of paint.

ACCEPTED METHODS OF SLINGING SILENCERS

Silencers that are not equipped with hinges, pins, or lugs can be handled by the following methods:

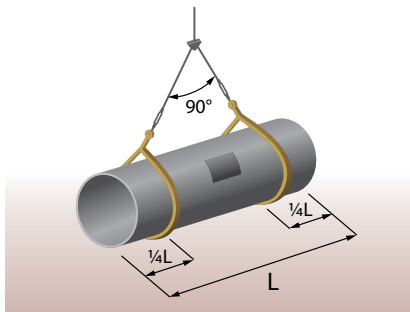

Free slinging of silencers for housing with the help of textile slings.

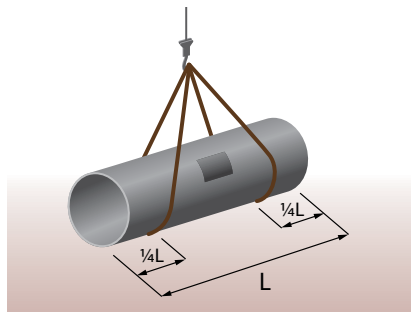

Free slinging of silencers for exhaust pipes with the help of a rope.

HANDLING

ACCEPTED METHODS OF SLINGING SILENCERS

Silencers that are not equipped with hinges, pins, or lugs can be handled by the following methods:

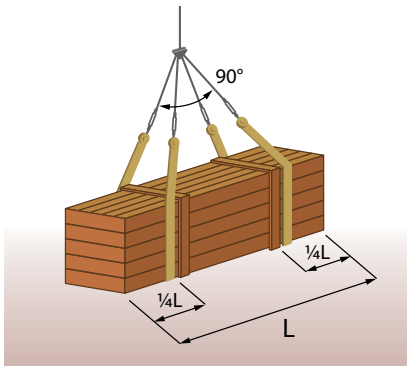

Free slinging of silencers in a wooden pallet box using textile slings.

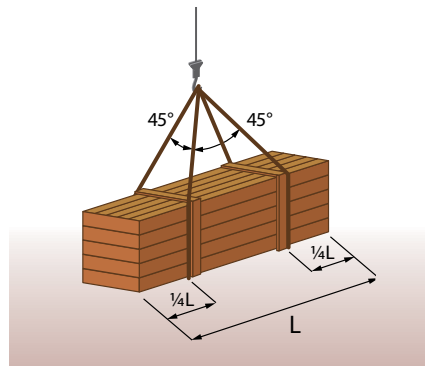

Free slinging of silencers in a wooden box with ropes.

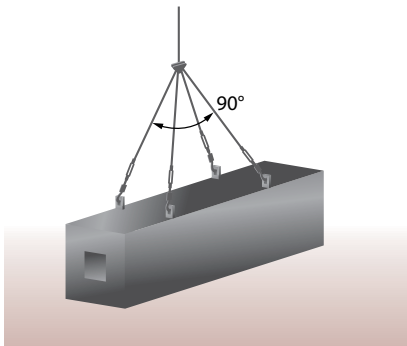

Rigid slinging of silencers in a container by means of wire ropes.

INSTALLATION

Unpack the silencer and make sure no paper, plastic or other unwanted object is inside the silencer. Before starting mounting the silencer please make sure that it is the correct silencer and that outer dimensions are as ordered.

The silencers are constructed so exhaust gas has to flow in a certain direction through the silencer to give the right sound reduction and the right back pressure. The flow direction is stated on the identification type plate as mentioned in chapter 4. A type plate positioned on the body of the silencer.

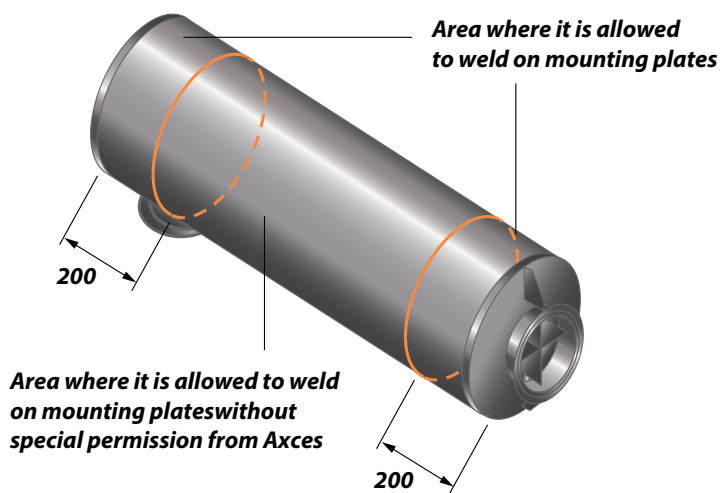

The silencer must be placed in the exhaust system in a way so that heat stresses do not have any influence on flanges. It means that heat expansions have to be eliminated by means of expansion bellows near the silencer or the silencer/pipes have to move freely in their supports. Please be aware that 1 mtr steel will expand by 1 mm if the temperature rises by 100°C.

If mounting plates must be welded on a silencer this is allowed in an area from the endplate and 200 mm up. Mounting brackets of lifting lungs have to be welded on a rolled strengthening plate 200 x 200 x 6 mm before mounted on the silencer. If it is necessary to weld mounting plates onto other places on the silencer please contact AXCES for advice.

INSTALLATION

SILENCER LOCATION/POSITION

- The silencers can be installed either vertically or horizontally, depending on the given flow direction.

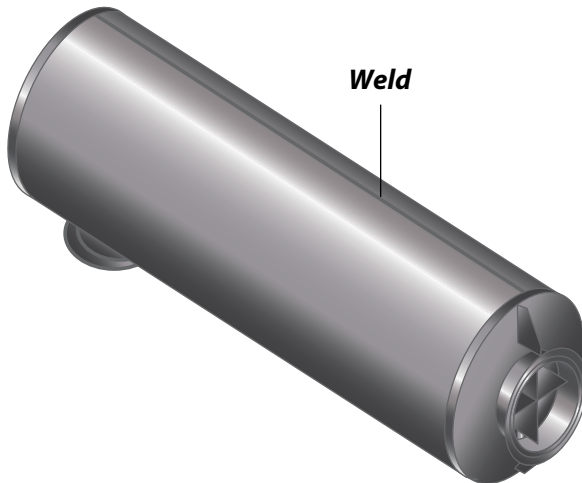

- Single silencer (4) may be installed anywhere between the engine (1) and halfway to the exhaust gas system, preferably as close as possible to the engine.
- The primary silencer (4) as described above with double silencers, the secondary silencer (4) anywhere between halfway to the exhaust gas system and the exhaust; preferably as close as possible to the exhaust opening.

INSTALLATION

THE LAYOUT OF THE MAIN COMPONENTS OF THE GAS EXHAUST SYSTEM

- 1 Internal combustion engine
- 2 Exhaust gas bellow
- 3 Fixed anti-vibration mountings
- 4 Suspension Pendulum type
- 5 Flexible hose
- 6 Silencer or spark arrestor
- 7 Identification label
- 8 Exhaust gas bellow
- 9 Deck fitting
- 10 Flexible pipe run
- 11 Protective rain cap of deck fitting
- 12 Rain shutter

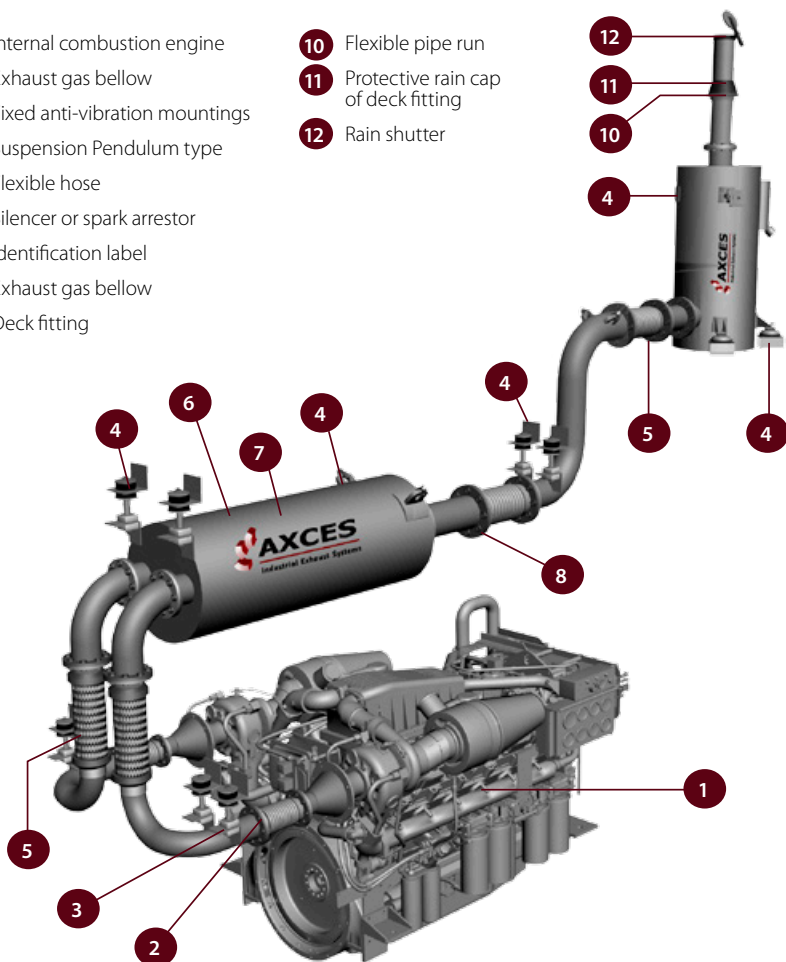

INSTALLATION

ELEMENTS OF FLUE

- Use flexible connections when connecting condenser tubes and carbon dioxide supply pipes (CO) to the corresponding connections of the muffler, spark arrestor muffler or spark arresters.
- When the equipment is placed outdoors fittings mentioned above should be adequately insulated.
- During the trace condensate drain system, the use of strictly horizontal (not oblique) areas is not allowed. The system should also be equipped with condensate traps, which should be installed in the lowest point of the pipeline.

ANTI-VIBRATION MOUNTINGS FLUE

- Use vibration-free installation process during the cabling gas exhaust piping system.
- The type and amount of vibration props and hangers of gas exhaust system must be determined on the strength of static and dynamic loads considering the direction of thermal movement of the duct on the basis of the recommendations of the muffler manufacturer.
- Hanger pendulum type PAX+VOAX series should be placed at an angle of 45° to the Y axis of the muffler or flow direction.
- Position the suspension pendulum PAX series on the surface of the muffler or flow direction.
- Still OAX series anti-vibration mountings are mounted so that during loading force on the damper is in the axial direction necessary, and the elastic element working strictly in tension.
- Still OAX series anti-vibration mountings are mounted so that during loading force on the damper is in the axial direction necessary, and the elastic element working strictly in compression.

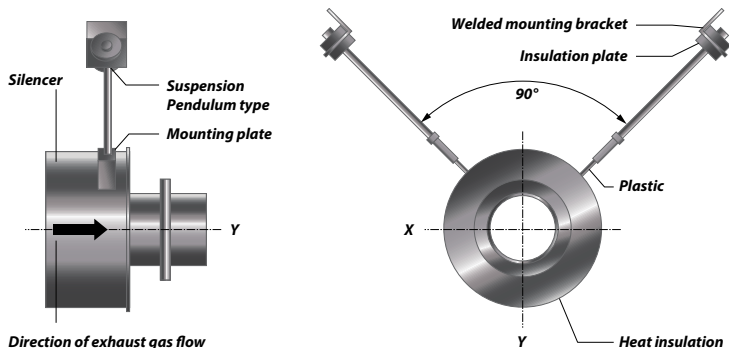

INSTALLATION

INSTALLATION RECOMMENDATIONS

- Weld seam preferably on the top when horizontal installed.
- For optimal performance, the complete exhaust gas system must be installed vibration-free.
- The silencer (6) and the complete exhaust gas system must be installed vibration-free for optimum performance.
- Sufficient attention must be carried out to the use of (a) compensator(s) for coping with expansions and excessive vibrations.
- A fixed point (3) must be placed directly behind the engine compensator to alleviate the engine compensator when starting and stopping the engine (1) and to limit line resonance as much as possible.
- Any condensate tapping device (the drain) must be at the lowest point.
- Provide correct acoustic dismantling if the condensate tapping point is connected to a drain line.
- Always provide a smooth flow through the lines and avoid right angled bends and/or other abrupt flow changes to prevent unnecessary pressure loss.
- If the silencer is provided with a spark arrester, install the silencer so that the spark collector can be regularly cleaned.
- If the silencer is installed on and/or via flexible (rubber) supports and/or suspension, provide sufficient ventilation to prevent overheating of the rubber. The suspension points must therefore not be shortened too far. Also look carefully at the installation of the “thermoplaque” insulators below and above the supports.
- If an exhaust gas pipe has to be fed through a wall, it is preferable for a partition duct to be used.
- If an exhaust gas pipe has to be fed through a deck, it is preferable for a deck duct (9) to be used.
- If the extraction section is installed vertically, it is preferable for a hood (10+11) to be used.
- It is recommended to check the bolt connections after the installation has been at operating temperature several times.

INSTALLATION OF SPARK ARRESTOR SA

POSITIONING

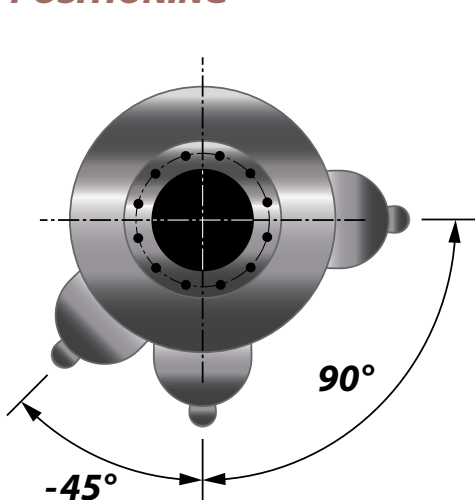

HORIZONTAL

Soot box needs to be situated between -45° and 90°



VERTICAL

Soot box needs to be situated with plug facing downwards

INSTALLATION OF SPARK ARRESTOR CP

POSITIONING

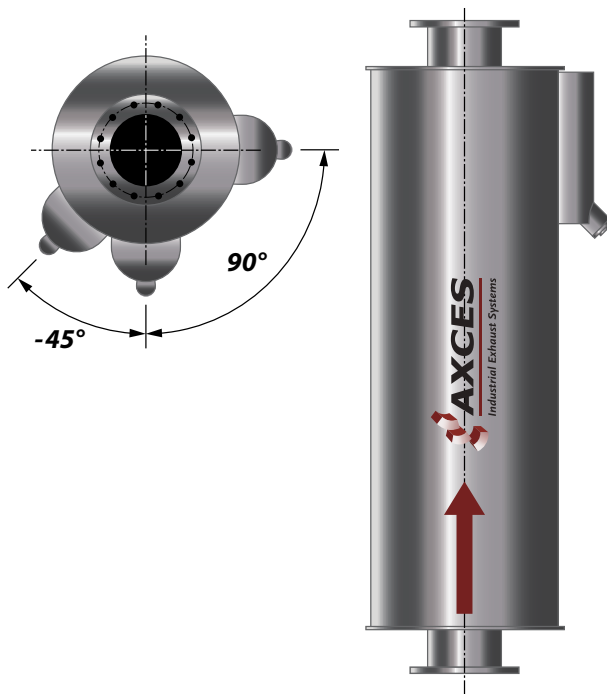

HORIZONTAL

Soot box needs to be situated between -45° and 90°

VERTICAL

Soot box needs to be situated with plug facing downwards

CLEANING INSTRUCTIONS FOR SPARK ARRESTORS

SOOT CLEANING is compulsory and must be performed every six months.

The following **PRECAUTIONS** must be respected.

- The exhaust silencer or parts thereof may be hot. Injury danger.
- Exhaust gasses are poisonous. Do not inhale.

PROCEDURE

- If the engine runs, stop the engine.
- Remove the plug from the soot box.

OPTION 1

- Connect a socket extended with a rubber hose. The hose must end outdoors or at least in a properly ventilated space.
- Use a container to collect the soot.
- Start the engine and partly cover the tail pipe to increase pressure in the exhaust system. The soot will flow along with exhaust gasses through the rubber hose.

OPTION 2

- Connect the socket to a vacuum cleaner and vacuum clean the soot box.
- Install the plug back into the soot box socket.
- Check for proper sealing of the plug so there are no leaks.

It is advisable to clean the spark arrestor with compressed air once per year.

WARNING/ DANGER



Maximum permissible back pressure 15 kPa.



Exhaust gases are always toxic, even after the installation of a catalyst and/or soot trap.



Always make sure that the flange connection is tightened, gaskets are intact and inspect the silencer frequently to ensure that no leaks occur. If leaks do occur the engine has to be brought out of service immediately and leak repaired.



Exhaust gas systems (including the silencer) contain very hot parts when operational and for a long time after use. During operation of the engine the surface of the silencer will reach a dangerous high temperature as high as up to 500°C. Normally local authorities demand isolating of such systems with max. surface temperature below 60°C. If surface temperatures during operation reach a higher temperature than 60°C precautions must be taken to prevent intentional or unintentional contact with the surface.



Never remove drain plugs, other cleaning plugs or inspection hatches during operation.



Incorrect handling of the silencer can involve a risk of damage to persons during transport and mounting of the silencer. Always use approved lifting gear and follow the guide lines of the equipment used by handling procedure for the silencer.

FIRST AID BURNS

COOL THE BURN Hold the burned area under cold running water until the pain subsides.

CAUTION Do not use ice. Putting ice directly on a burn can cause frostbite, further damaging your skin.

Do not break blisters. Broken blisters are vulnerable to infection.

FOR MAJOR BURNS Call for emergency medical assistance. Until an emergency unit arrives:

CHECK FOR SIGNS OF CIRCULATION (BREATHING, COUGHING OR MOVEMENT).

If there is no breathing or other sign of circulation, begin cardiopulmonary resuscitation (CPR).

FIRST AID CO/CO₂-POISON

CO and CO₂ is an odour- and colorless gases and therefore impossible to discover without special measurements.

IF POISONED Bring the person out in fresh air. Call for emergency medical assistance.

MAINTENANCE

When the engine is tuned according to the data of the engine manufacturer, the silencer needs to maintenance. In case a spark arrester is installed, remove every half-year the nut of the soot container, and clean the inside. Silencers have to be inspected every year. Following items have to be observed:

- Bolts have to be tightened up
- Suspensions visually inspected
- Silencer inspected for rust
- System examined for leaks

If the silencer is provided with a spark arrester, this must be cleaned at least once every 2 months.

AXCES EXHAUST SILENCERS

THE AXCES GROUP

The Axces Group consists of a total of eight companies. All focussed and highly specialized around the design, engineering, production and fitting of exhaust gas systems for use in the Marine, Industrial and Energy markets.

Whether you choose complete Fully- Integrated Exhaust Systems , Water Injected Exhaust Systems, Emission Control or more limited solutions, you will always benefit of Axces' competence and knowledge!



AXCES Wet Exhaust Systems

Ondernemersweg 12
4691 SL, Tholen, The Netherlands
+31(0)166 603 285 - info@axceswetsystems.com
www.axceswetsystems.com

AXCES Emission Technology

Ondernemersweg 12
4691 SL, Tholen, The Netherlands
+31(0)166 603 285, F +31(0)166 603 268
info@axces.com - www.axces.eu

AXCES Production

MŁYNY 16B
37-550 RADYMNO, Poland
+48(0)603 676 903 - info@axces.pl
www.axces.pl

AXCES Asia (Singapore)

No. 7 , Toh Guan Road East
#07-07 Alpha Ind. Building, Singapore
+65 6569-0570 - info@axces.sg
www.axces.sg

AXCES Holding

Havenpark 33
4301 JG, Zierikzee, The Netherlands
+31(0)166 603 285 - info@axces.com
www.axces.com

AXCES Industrial Stacks

Ondernemersweg 12
4691 SL, Tholen, The Netherlands
+31(0)166 603 285 - info@axces.com
www.axces.com

AXCES Exhaust Systems

Ondernemersweg 12
4691 SL, Tholen, The Netherlands
+31(0)166 603 285 - info@axces.com
www.axces.com