

1 2 3 4 5 6 7 8 9 10 11 12

A

A

B

B

C

C

D

D

E

E

F

F

G

G

H

H

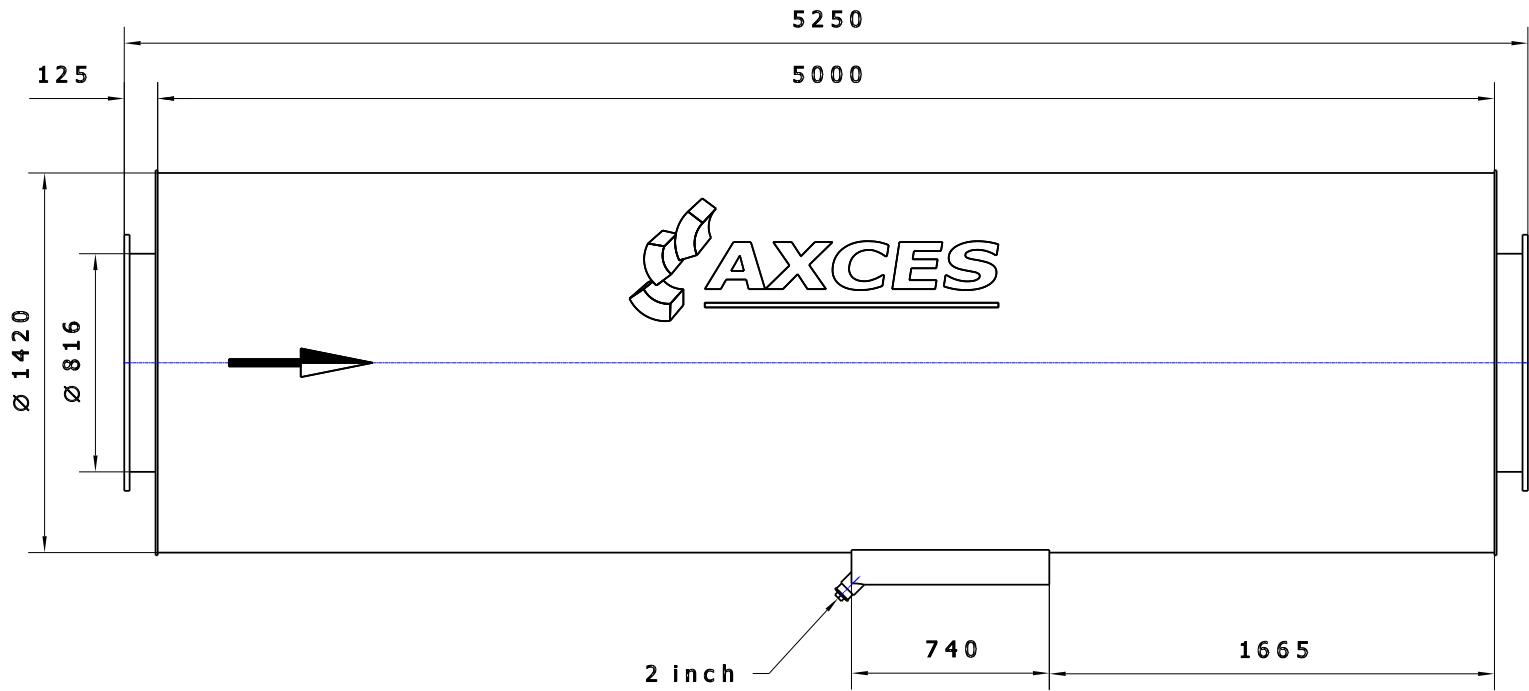
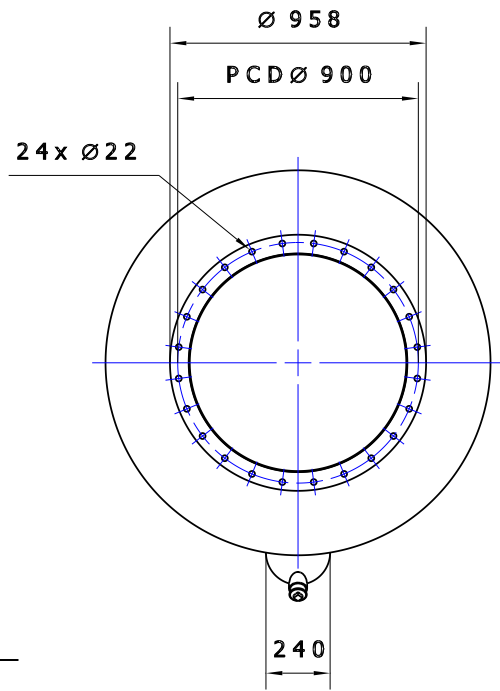

<b>MATERIAL</b> MILD STEEL S235JR				B	---	-	-	
<b>FLANGES</b> DIN 86044				A	-	-	-	
<b>COATING</b> SILICONE PAINT - THERMORESISTANT UP TO 800°C, SILVER				MOD	DESCRIPTION		DRAWN	DATE
<b>WELDING QUALITY ACC. TO EN-ISO 5817 CLASS C</b>						AXCES B.V. Ondernemersweg 12 4691 SL Tholen The Netherlands www.axces.com +31 (0) 166 603 285		ALL RIGHTS RESERVED THIS DRAWING SHALL NOT BE REPRODUCED WITHOUT THE PRIOR PERMISSION OF AXCES B.V.
<b>TOLERANCES ACC. TO EN-ISO 13920 CLASS B,F</b>						NUMBER OF SHEETS 1		DATE 2013-10-31
<b>DIMENSIONS</b>	<b>LENGTH</b>	<b>ANGLE</b>	<b>STRAIGHTNESS FLATNESS PARALLELISM</b>	<b>TITLE</b>		<b>DRAWING NUMBER</b>		<b>DRAWN</b>
400 mm	± 2 mm	± 45'	± 1,5 mm	EXHAUST SILENCER		181113/REAB35-IS/32		ES
1000 mm	± 3 mm	± 30'	± 3 mm	TYPE		SPARK ARRESTOR		DAMPING
2000 mm	± 4 mm	± 20'	± 4,5 mm	REAB35-IS-32" (NB800)		BUILT-IN		35 dB(A)
4000 mm	± 6 mm	± 20'	± 6 mm	PROJECTION		WEIGHT		SCALE
>4000 mm	± 8 mm	± 20'	± 8 mm			1175 Kg		1 / 20
								FORMAT
								A3

1 2 3 4 5 6 7 8 9 10 11 12