

Advantages of a SCR System With Integrated Silencer and Type Approved Spark Arrestor

- ✔ Prepared Silencer to SCR
- ✔ Attenuation > 45 dB(A)
- ✔ Minimum Back Pressure
- ✔ NOx Reduction > 80%
- ✔ Vanadium Based Catalyst
- ✔ Custom Made Design
- ✔ Built in Spark Arrestor
- ✔ Certified High Class Materials
- ✔ Manufactured by AXCES

Silencer Convertable to SCR Catalyst

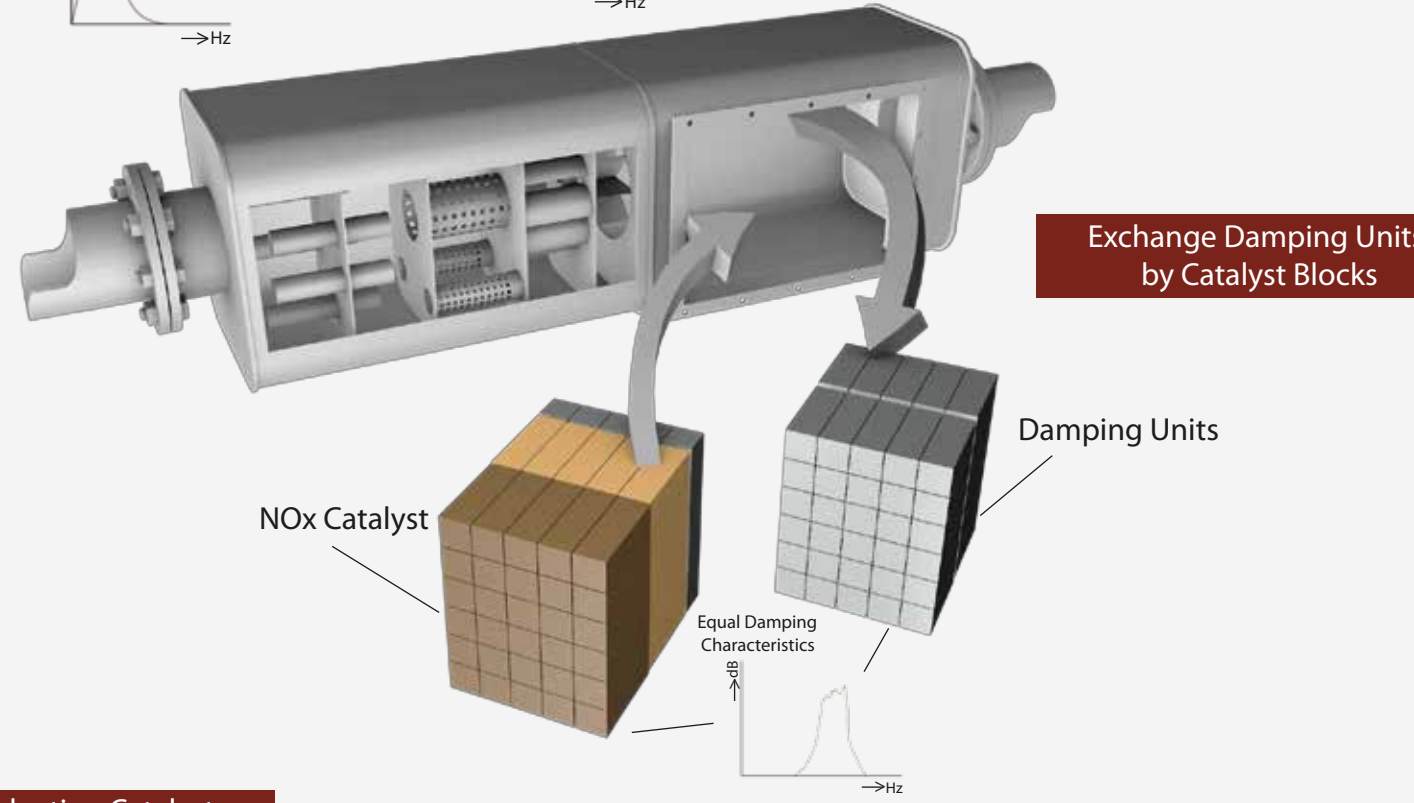
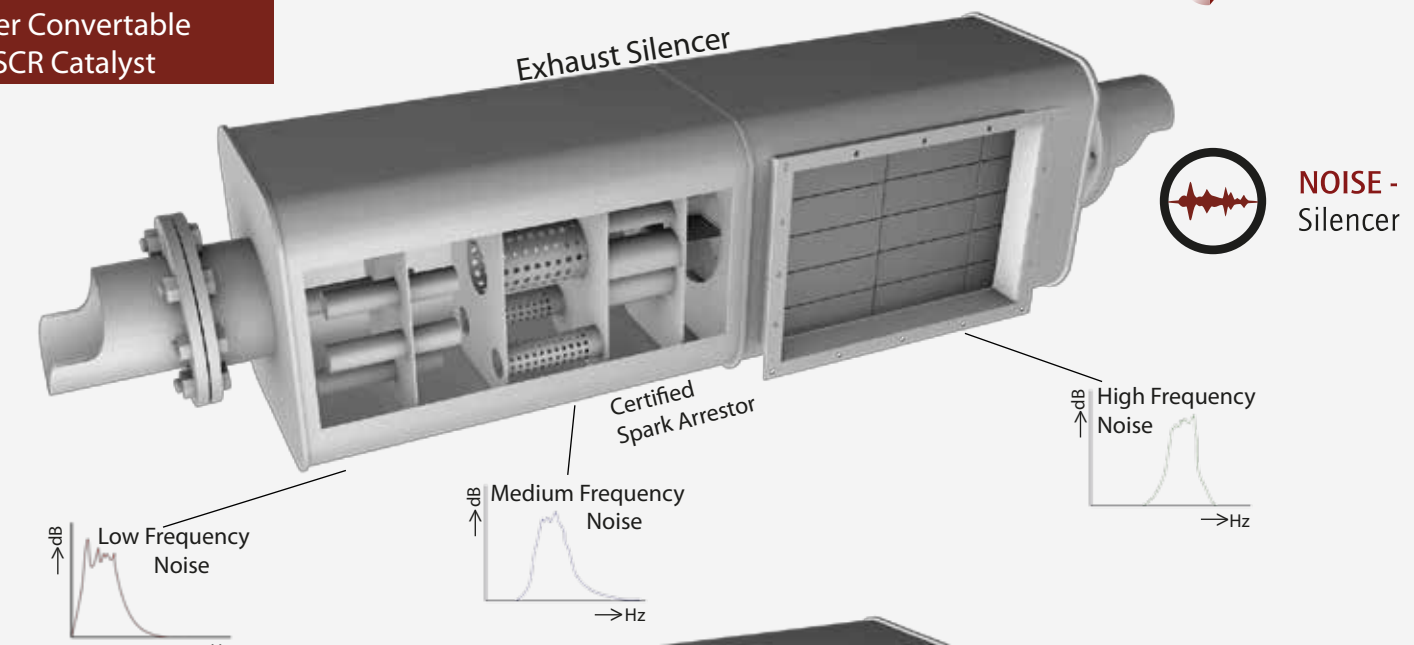

NOx Reduction Catalyst and Integrated Silencer

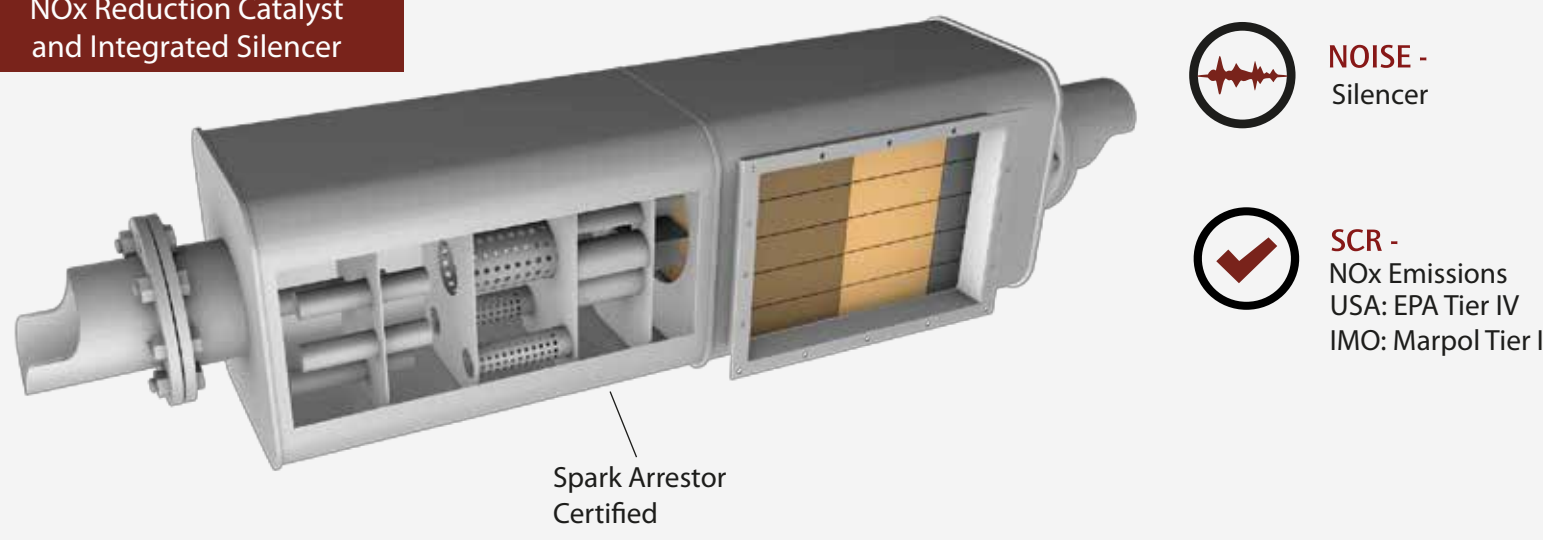

Moving forward towards 2016 and in-line with current EPA and IMO standards, regulating the release of harmful NOx compounds from exhaust systems.

The integrated SCR/silencer reactor is a novel solution making AXCES a market leader in this field. The new IDE - NOx reactor can be swapped with the existing noise reduction elements.

This upgrade of reactor leads to a reduction in the release of toxic NOx compounds through selective catalytic reduction, at the same time operates as a exhaust silencer.





**AXCES**

**INTEGRATED NOISE & EMISSION TECHNOLOGIES**

Ondernemersweg 12  
4691 SL Tholen  
The Netherlands

No. 7, Toh Guan Road East  
#07-07 Alpha Ind. Building  
Singapore (608599)

**T** +31(0)166 603 285  
**F** +31(0)166 603 268  
**E** info@axces.com

**T** +65 6569-0570  
**F** +65 6569-0592  
**E** info@axces.sg

[www.axces.com](http://www.axces.com)

[www.axces.sg](http://www.axces.sg)

